

Serie MSP – MONTAGGIO CON BULLONE

Codice	Carico max. (kg)	Ø sfera	A	B	C	D	E	F
MSP10	20	12	20	29.8	17.8	3	12	M8 × 1.25
MSP11	25	12	20	48	20	3	28	M6 × 1.0
MSP12*	20	12	22	42.5	22.5	3.5	20	M8 × 1.25
MSP14	50	15	24	32.5	20.5	3.9	12	M6 × 1.0
MSP15*	50	15	25	46	26	5	20	M8 × 1.25
MSP19	75	19	30	46.5	26	4.8	20.5	M8 × 1.25
MSP22	180	22	36	62.9	37.5	2.6	25.4	M12 × 1.75
MSP30	350	30	45	69.2	43.8	6.5	25.4	M12 × 1.75
MSP45	600	45	62	107.3	66	8.5	41.3	M20 × 2.5

* Indica il cappello premuto.

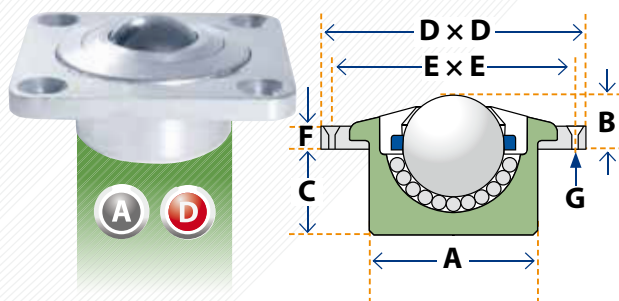
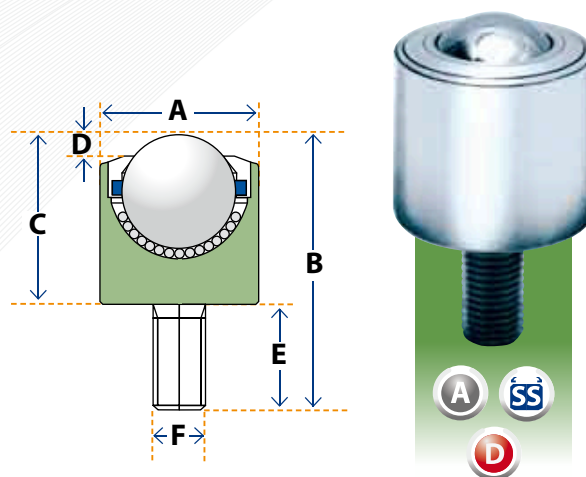

Serie MS – FLANGIA SUPERIORE

Codice	Carico max. (kg)	Ø sfera	A	B	C	D × D	E × E	F	G
MS12*	20	12	23.9	9.6	11.1	44.5#	34.9	3.2	2 × 3.6
MS15*	50	15	24	11.3	9.7	45	32	4.8	4 × 4.6
MS22	180	22	36	11.8	18.7	57.2	44.5	4.8	4 × 5.6
MS30	350	30	45	16.8	20	76.2	57.9	6.3	4 × 7.1
MS45	600	45	62	22	31.5	85	69	9.5	4 × 7.1

MS 12 ha una flangia circolare da 44.5 mm con 2 fori di montaggio.

* Indica il cappello premuto.

Serie MF – FLANGIA INFERIORE

Codice	Carico max. (kg)	Ø sfera	A	B	C	D	E × E	F × F	G	H
MF12*	20	12	23.9	20.7	17.2	3.5	44.5#	34.9	3.2	2 × 3.6
MF15*	50	15	25	21	16	5	45	32	4.8	4 × 4.6
MF22	180	22	36	30.5	27.9	2.6	57.2	44.5	4.8	4 × 5.6
MF30	350	30	45	36.8	30.3	6.5	76.2	57.9	6.3	4 × 7.1
MF45	600	45	62	53.5	45	8.5	85	69	6.3	4 × 7.1

MF 12 ha una flangia circolare da 44.5 mm con 2 fori di montaggio. * Indica il cappello premuto.

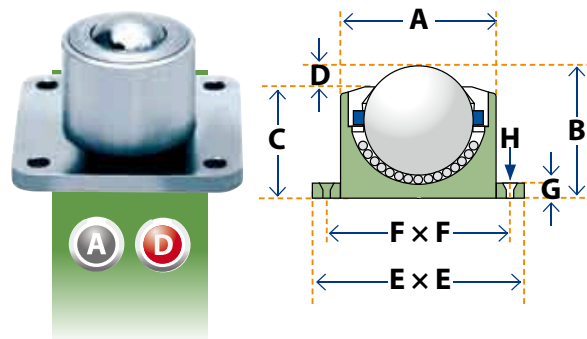

Serie MO – ATTACCO CON O-RING

Codice	Carico max. (kg)	Ø sfera	A	B	C	D	E	F
MO15*	50	15	24	21	11.5	9.5	2	31
MO22	180	22	36	30.5	20.7	9.8	3	45
MO30	350	30	45	36.8	23	13.8	4	55
MO45	600	45	62	53.5	34.5	19	5	75

* Indica il cappello premuto.

