

Owner's Manual

**BOSE® 901 SERIES IV**

Direct/Reflecting® Speaker System

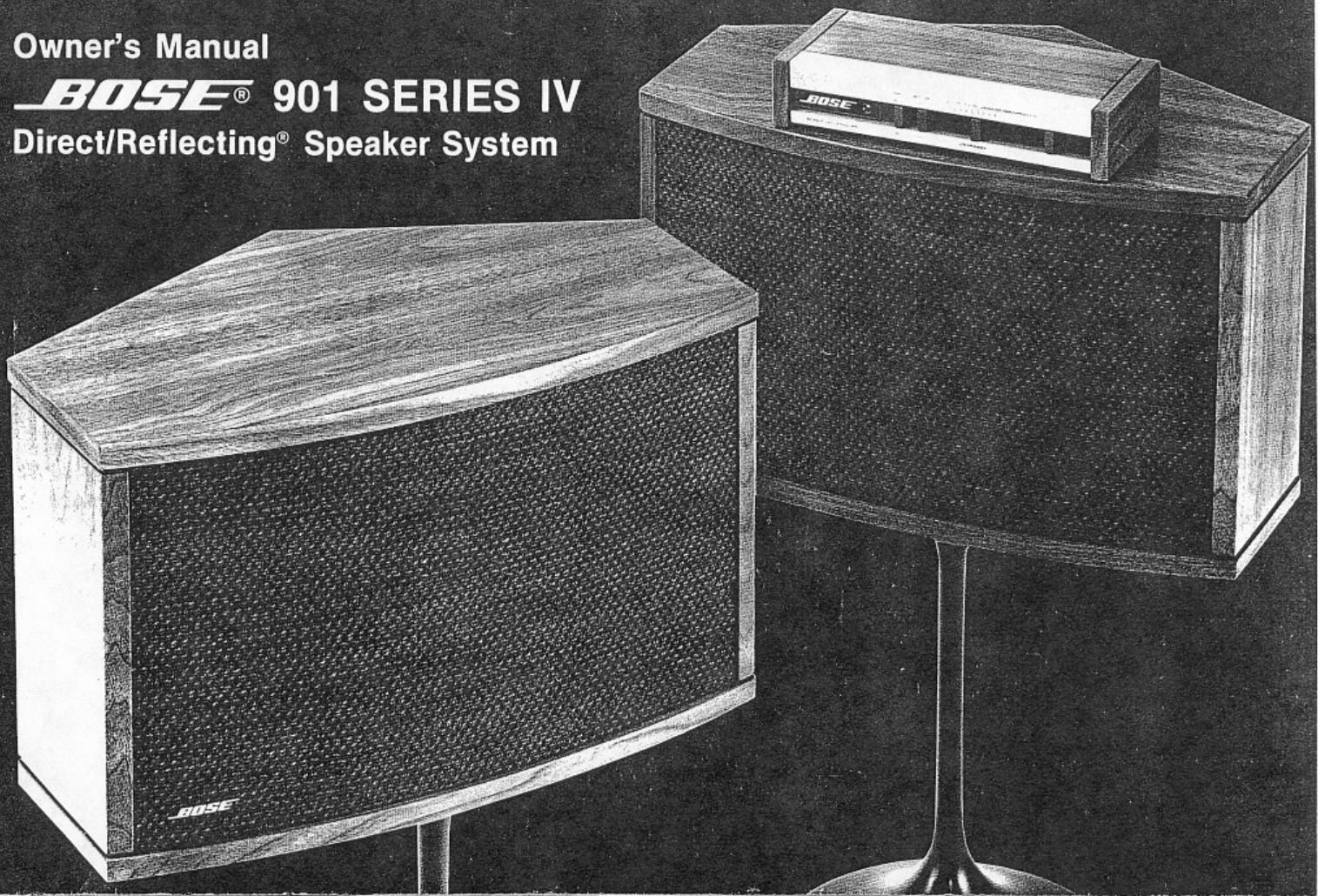

## Table of Contents

<b>I. Introduction</b>	<b>3</b>
<b>II. Unpacking Instructions</b>	<b>3</b>
<b>III. Installation</b>	<b>4</b>
A. Placing the Speakers	
B. Connecting the Speakers	
1. Wire Selection	
2. Phasing/Wiring	
3. Fusing	
C. Connecting the Equalizer	
1. Using the Tape Monitor Circuit	
2. Using Separate Components: Connecting Between the Preamp and the Amplifier	
3. Using the Preamp-Out/Main-In Circuit	
4. Using Four-Channel Equipment	
<b>IV. Connecting Other Equipment</b>	<b>12</b>
A. Tape Recorders	
B. Headphones and Conventional Speakers	
<b>V. Living with your BOSE 901 Speakers</b>	<b>14</b>
A. Source and Room Compensation Controls	
B. Adjusting the Source and Room Compensation Controls	
C. Speaker Placement	
D. Room Acoustics	
<b>VI. Technical Information</b>	<b>17</b>
A. Specifications	
B. Voltage Conversion	
C. In Case of Difficulty	
D. Care and Maintenance	
<b>VII. Warranty</b>	<b>19</b>

© 1978 BOSE Corporation. Covered by patent rights issued and pending.



## I. Introduction

Thank you for purchasing the BOSE 901 Series IV Direct/Reflecting® speaker system. The listening enjoyment you will experience is the culmination of many years of research dedicated to the art of bringing superb musical reproduction into the home.

The BOSE 901 Series IV, with its high proportion of reflected sound, nine full-range drivers, and a newly-designed electronic active equalizer, is installed, connected, and operated differently than conventional loudspeakers. The detailed installation and placement instructions found in this manual are important. PLEASE TAKE THE TIME TO READ THESE INSTRUCTIONS CAREFULLY. With proper installation, you will be rewarded with the unique listening pleasure provided by your 901 speakers.

## II. Unpacking Instructions

The 901 Series IV speaker system is packed in two cartons marked "Part 1" and Part 2." The active equalizer is found in the carton filler material along with the "Part 1" speaker. Unpack both cartons carefully. Save the cartons and packing material for possible use later. If either of the speakers has visible damage when unpacked, do not place the damaged speaker(s) in operation. Repack the speaker(s) in the original carton with the complete packing material and notify your dealer immediately.

### III. Installation

Your 901 Series IV speaker system consists of three parts: two speakers (marked "Part 1" and "Part 2") and an electronic Active Equalizer packed in the "Part 1" container. Installation consists of three steps: 1) placing your speakers for best sound, 2) connecting the speaker to your amplifying equipment, and 3) connecting the equalizer to your amplifying equipment.

If you place the speakers within the ranges suggested here, the unique adjustments found on the 901 Series IV equalizer will allow you to achieve optimum performance. (See SECTION V).

#### A. PLACING THE SPEAKERS

Unlike conventional speakers, the 901 Series IV functions with the acoustics of your listening room, simulating the spatial characteristics of the larger environments associated with a live performance. This important advantage allows considerable freedom of placement and produces an unusually large "best listening area." Outstanding performance can be obtained under a wide variety of placement positions. (See Figure 2.)

The following guidelines in placing the speaker cabinets will help you obtain the *best* performance. The basic idea is to provide space to allow the sound to develop around the speaker system.

1. The angled grille panels found on the enclosure are the rear face of the 901 speaker (see Figure 1). Point this portion of the speaker toward the reflecting wall (the wall behind the speaker). The point of the "V" should be between 12" and 24" from the reflecting wall. Best results will be obtained with the speakers placed between 12" to 18" from the reflecting wall.
2. Speakers should be placed at least 18" above the floor or below the ceiling (see Figure 1). Distances closer to the ceiling or floor restrict the reflected sound energy.

3. The speakers should be at least 18" from a side wall or opening into an adjacent room. (Suggested distances are 3' to 5'.) Large objects (such as furniture) should be at least 24" away from the side of the speaker.

4. Best results will be obtained with the speakers spaced apart 6' to 10'; however, separation as small as 3' or as great as 15' will give excellent results in most rooms.

If you have not decided where to place your speakers and would like more information, SECTION V (LIVING WITH YOUR BOSE 901 SPEAKERS) provides several additional suggestions for speaker placement.

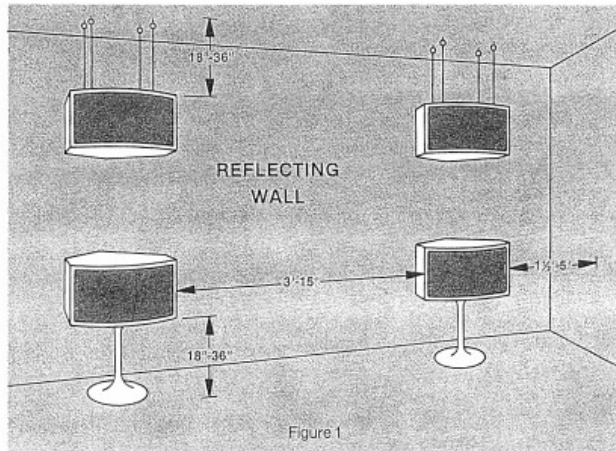

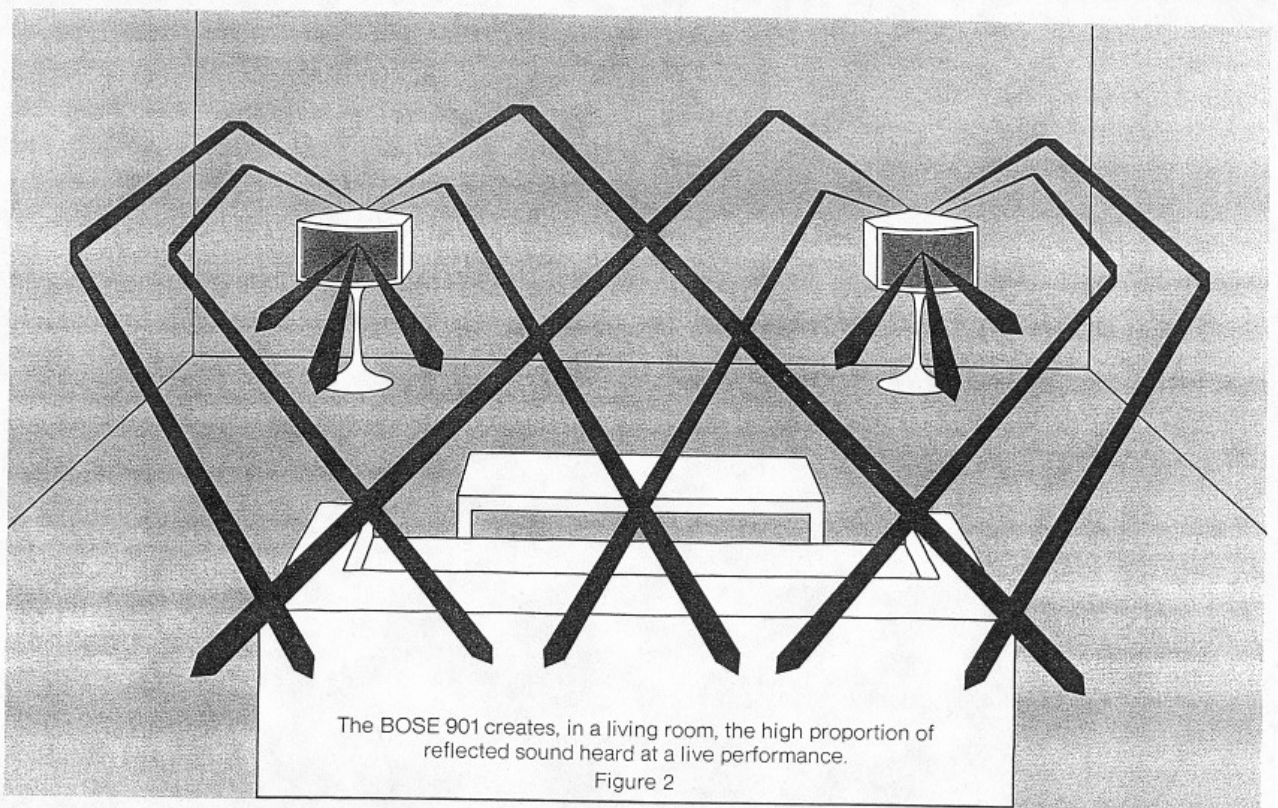

## Installation

### B. CONNECTING THE SPEAKERS

#### 1. Wire Selection

If the wire used to connect the speakers to your power amplifier has too much resistance, audible coloration of the sound and loss of power can result. The table below summarizes maximum wire lengths for 18-, 16-, and 14-gauge, two-conductor, stranded copper wire for use with one or two pairs of BOSE 901 loudspeakers.

TABLE 1  
RECOMMENDED CONNECTION WIRE†

Wire Length One Pair of 901s	Wire Length Two Pairs of 901s	Type of Speaker Hook-Up Wire
27 feet	13 feet	18-gauge zipcord (or two-conductor wire)
42 feet	21 feet	16-gauge two-conductor wire
67 feet	34 feet	14-gauge two-conductor wire

In most instances, copper zip-cord, readily available at most electrical and hardware stores, can be used for speaker connection. This wire usually has a ribbed line(s) along one side of the insulation so that each wire can be identified for proper phasing of your speaker system.

†The wire lengths shown in Table 1 were calculated on the basis of a maximum audible coloration of  $\pm 0.5$  dB. Following the guidelines provided, the most discerning listener will be unable to detect any coloration introduced by the speaker wire. Most listeners will not notice any effect even if wire lengths are increased by as much as 50%.

#### 2. Phasing/Wiring

It is important that the amplifier connections for both 901 speaker systems be identical (see Figure 3) so that both speakers work together (in phase).

- Start with the speaker marked "Part 1."
- Place it on the left side of your room facing the speaker system.
- Locate the "+" and "-" terminals on the bottom of the speaker.
- Using the speaker wire (which is marked to distinguish one conductor from the other), connect the "Part 1" speaker terminal marked "-" to the terminal marked "com," "negative," or "minus" on the left channel amplifier output. (When connecting the 901 Series IV loudspeakers to your amplifier, if there is a choice of impedances on the amplifier output, use the terminal marked "8" or "8 ohms." If two pairs of 901 Series IV loudspeakers are being connected, the terminal marked "4" or "4 ohms" on the receiver or amplifier should be used.)††
- Connect the "+" terminal on the left speaker to the terminal marked "pos," "positive," or "plus" on the left channel output of the amplifier or receiver.  
NOTE: Use only the terminals marked "+" and "-." The terminal marked "\*" is intended for future electronic developments and should not be used with conventional amplifying equipment.

††Note: When operating your 901s in stereo, only one equalizer is required. If additional pairs of 901s are used, they can be purchased without the equalizer. These speakers are sold as "add-on" pairs and can be connected as extension speakers or used in addition to the first pair of speakers.

When connecting two pairs of 901 speakers to your equipment, wire the speakers in parallel; most recently manufactured receivers or amplifiers will operate two pairs of 901s wired in this manner. However, if your receiver or amplifier is not capable of 4-ohm operation with two pairs of 901s, wire the speakers in series. Contact your dealer if any further assistance is required.

- f. Place the speaker marked "Part 2" on the right side of the room and repeat the connection procedure for the right amplifier channel.
- g. If you are using an amplifier rated at over 100 watts rms per channel, fuse your speakers as outlined in SECTION 3.

### 3. Fusing

Any loudspeaker is subject to damage if the amplifier powering it should fail. The use of a fast-acting fuse in series with each speaker will minimize the possibility of serious damage to your speaker.

For amplifiers rated at under 100 watts rms per channel, no fusing is required. Amplifiers rated over 100 watts per channel should be fused with a fast-blow, 3-amp fuse.

Purchase fuseholders and the appropriate fast-acting fuses. Connect the fuseholders in series with the positive wire going to each speaker, placing the fuse in an easily accessible location.

Referring to the speaker connection diagram, the fuseholders should be inserted in the positive wire connecting each speaker. Be sure to place the fuse in an easily accessible location. BOSE Corporation recommends use of a 3-ampere, fast-acting Buss AGC Series or Littelfuse AG Series. A fuse kit containing fuses and holders can be obtained from BOSE Customer Service Department for \$5.00. Ask for part number 108938-3.

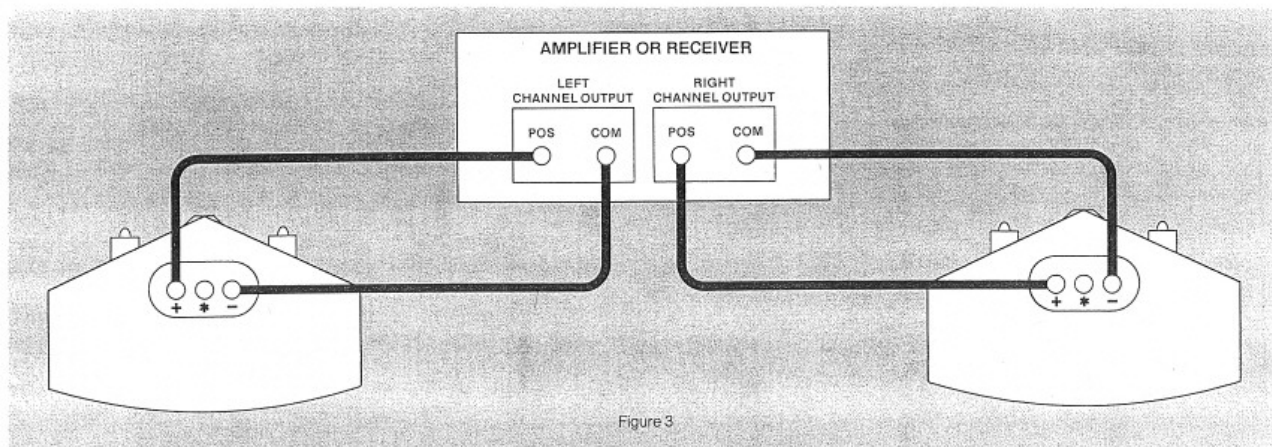

Figure 3

## Installation

### C. CONNECTING THE EQUALIZER

IT IS MOST IMPORTANT THAT YOU FOLLOW THESE INSTRUCTIONS FOR OPTIMUM PERFORMANCE OF YOUR 901 SERIES IV SPEAKER SYSTEM.

#### 1. Using The Tape Monitor Circuit

The connection methods described in this section can be used with virtually all integrated amplifiers, preamplifiers, and receivers.† Using the tape monitor circuit has two advantages: When using conventional loudspeakers or headphones, the tape monitor circuit allows disconnection of the Active Equalizer by turning off the tape monitor switch on your control amplifier; this is important because conventional speakers and headphones should not be used with the Active Equalizer. (See SECTION IV.) Also, optimum system noise performance is obtained when connecting the equalizer in the tape monitor circuitry.

When using this procedure, you should realize that the 901 equalizer is being connected to your equipment *as if it were a tape recorder*, using the tape monitor connections of your control amplifier.

NOTE: Check your control equipment to determine if your unit has any additional switching flexibility. Some recently introduced units now feature switching facilities called Tape Monitor 3, External Equalizer/Processing, or Noise Reduction Connections. The equalizer can be connected to these terminals allowing greater system flexibility if required.

†To make connection easier, we are going to refer to all of these various components as the "control amplifier."

Referring to FIGURE 4, connect the Active Equalizer according to the following instructions:

- a. Turn off all power to your high-fidelity system.
- b. If you have a tape recorder, disconnect it from your control amplifier.  
(Instructions in SECTION IV will tell you how to reconnect your tape recorder to the system after the equalizer has been installed.)
- c. Using one of the cables supplied with the equalizer, connect the LEFT channel OUTPUT of the equalizer to the LEFT or "A" channel of the tape monitor circuit of your control amplifier. (This terminal may also be labeled PLAYBACK or TAPE IN.)
- d. Connect the RIGHT channel OUTPUT of the equalizer to the RIGHT or "B" channel tape monitor connection of your control amplifier.
- e. Connect the LEFT channel INPUT terminal of the equalizer to the LEFT or "A" channel TAPE RECORD connection of your control amplifier. (This terminal may also be labeled TAPE OUT or REC OUT.)
- f. Connect the RIGHT channel INPUT connection to the RIGHT or "B" channel TAPE RECORD connection of your control amplifier.
- g. Plug the ac power cord of the equalizer into a "switched" ac outlet on your control amplifier so that the equalizer will automatically be turned on or off with the power switch of your equipment.

If the preceding steps are unclear, it may be due to the different nomenclature used by various manufacturers of amplifying equipment. Consult your control amplifier's instruction manual and refer to the section describing the connection of a tape recorder. Remember, the equalizer is connected just like a tape recorder.

THE FOLLOWING STEPS ARE PROVIDED TO ENSURE THAT THE EQUALIZER IS PROPERLY CONNECTED TO YOUR HIGH-FIDELITY SYSTEM.

- h. Place the TAPE switch of the equalizer in the MONITOR position.  
As you slide the LOW and HIGH FREQUENCY SOURCE AND ROOM COMPENSATION controls from one extreme to the other, you will find a detent in the middle of the control's travel. Place both the LOW and HIGH FREQUENCY SOURCE AND ROOM COMPENSATION controls at this position. Set the LOW FILTER control in the "out" position.
- i. Place the TAPE MONITOR or TAPE FUNCTION switch of your control amplifier in the NORMAL or OUT position.
- j. Turn your system on. (Be certain that the equalizer is plugged into the switched ac outlet of your control amplifier and observe that the pilot light on the equalizer is on.)

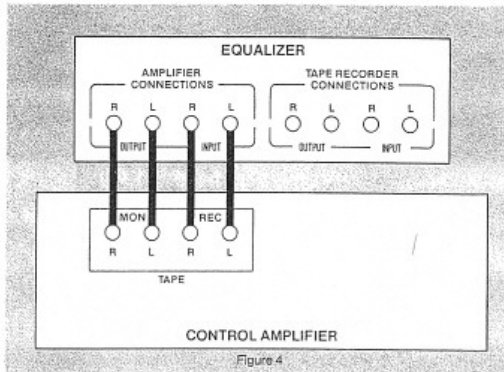

- k. Play the entire system as you normally would, using a record player or AM/FM source to be sure it is operating properly. (Do not use a tape recorder for this portion of the test.)

- l. Turn the BALANCE control of the control amplifier to the extreme left and right to check for proper connection of the left and right channels. (If the channels are reversed, check your amplifier or speaker connections carefully.)

You have now tested the amplifier, wiring, and speaker systems, but not the equalizer, as it is not yet switched into the system.

If your system is not functioning at this point, please go back and check all connections, as any errors in connection of your system must be corrected before proceeding further.

- m. With the system now playing, turn the TAPE MONITOR or TAPE FUNCTION switch on your control amplifier to the MONITOR or ON position. *The sound should stop.* If the sound does not stop, recheck Steps "a" through "l."

- n. Now, place the equalizer TAPE switch in the NORMAL position. The sound should now return. If the sound does not return and the equalizer pilot light is on, then the equalizer is probably connected incorrectly. Recheck Steps "a" through "l."

NOTE 1: THE TAPE MONITOR OF YOUR CONTROL AMPLIFIER MUST BE LEFT "ON" FOR THE ACTIVE EQUALIZER TO BE IN THE CIRCUIT. CHECK THE TAPE MONITOR SWITCH PERIODICALLY TO MAKE CERTAIN IT IS IN THE "ON" POSITION.

NOTE 2: THE 901 SERIES IV AND III EQUALIZERS ARE NOT COMPATIBLE WITH THE 901 SERIES I AND II SPEAKER SYSTEMS. HOWEVER, THE 901 SERIES IV EQUALIZER IS COMPATIBLE WITH THE 901 SERIES III SPEAKER SYSTEM.

## Installation

### 2. Using Separate Components, Connecting Between the Preamp and the Amplifier

The equalizer can be connected between separate preamplifier and power amplifier units (see Figure 5). This connection method provides complete flexibility of the preamplifier tape monitor functions for use with one or two tape recorders in the conventional manner. The disadvantage of this connection method involves using conventional loudspeakers and headphones because the equalizer is permanently wired into the circuit. (See SECTION IV.) If you do connect the equalizer in this manner, it is suggested that the gain controls of your power amplifier be reduced slightly from fully clockwise for optimum system noise (consult your amplifier owner's manual for further recommendations).

### 3. Using the Preamp-Out/Main-In Circuit

An alternate method of connecting the BOSE Active Equalizer makes use of the PREAMP-OUT and MAIN-IN jacks provided by many manufacturers on their receivers or integrated amplifiers (see Figure 6). Using the PREAMP-OUT/MAIN-IN connection jacks retains the total flexibility of the tape monitor circuitry. However, this method of connection permanently connects the equalizer in the circuit; this may prove inconvenient if you are using conventional speakers or headphones. (See SECTION IV.) Due to the circuitry characteristics of some receivers, the equalizer may not function if connected to these jacks. Also, system noise may increase slightly due to the connection of the equalizer immediately before the power amplifier input.

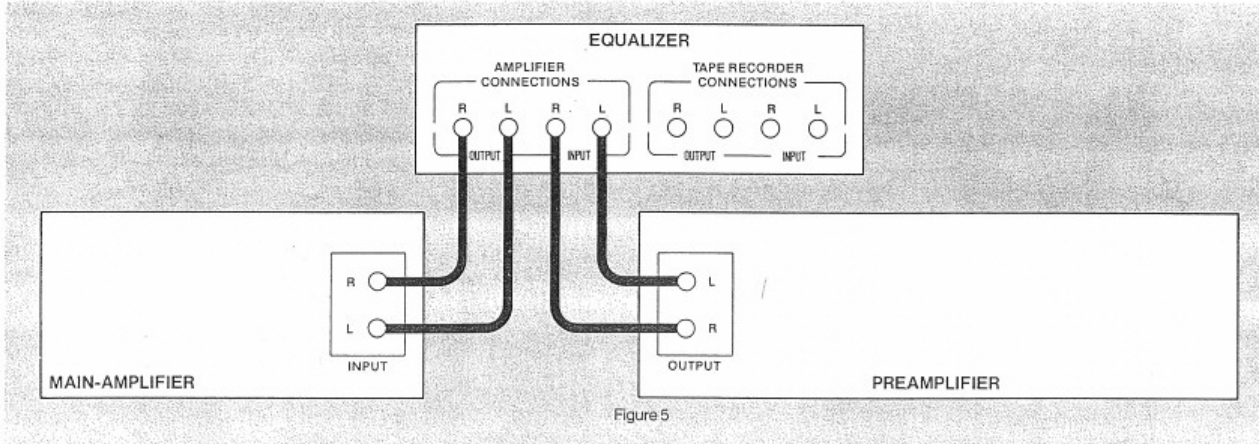
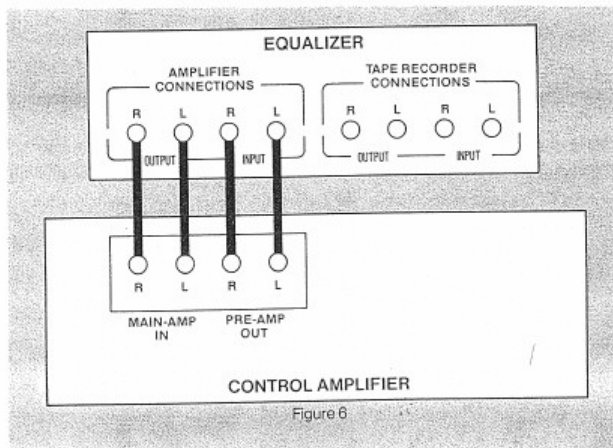

Figure 5

To use this method of connection, refer to your receiver and integrated amplifier owner's instruction manual for separating the main and preamplifier sections of the unit. (This is usually accomplished by removing shorting wires or plugs and/or moving a slide switch.) Connect the PREAMP-OUT terminals to the equalizer INPUT terminals, and connect the EQUALIZER OUTPUT terminals to the MAIN-IN terminals of the receiver or integrated amplifier (see Figure 6). With this method of connection, do not use the tape recorder connection jacks on the equalizer and leave the TAPE switch (on the equalizer) in the NORMAL position. Tape recorders are now connected to the receiver or amplifier in the conventional manner.



#### 4. Using Four-Channel Equipment

Most quadraphonic receivers have four-channel tape monitor or preamp out/main in connection jacks. These connection jacks can be used for the BOSE equalizer.

If two pairs of 901s are used, two active equalizers are required. Connect one equalizer for the front channels and one for the rear channels.

If conventional speakers are used with the 901s, connect the equalizer in the channel powering the 901 speakers. For the channels operating the conventional speakers, use standard connection cables and connect the input to the output jacks directly.

Phase reversal occurs when the 901 equalizer is connected in the circuit. For this reason, your control amplifier's speaker phasing procedure should be repeated when using conventional speakers with the BOSE 901's. This important procedure involves listening to musical passages with deep bass to determine the proper phase of your speakers. In most cases, this will require the reversal of one pair of speaker connections.

For separate components, connect the equalizer after the output of the decoder. We suggest reading the related sections of this manual before proceeding. Also, be certain to recheck your speaker phasing.

**Note:** Due to the spatial and spectral properties of the 901 Series IV system, optimum performance is obtained when all four speaker systems are identical. However, if four 901's are not used, we suggest using speakers having similar spatial characteristics, such as the Bose Direct/Reflecting® 601 or Model 501 speaker systems. These speaker systems have been designed by Bose to match the 901 system when used in quadraphonic operation.

## IV. Connecting Other Equipment

### A. TAPE RECORDERS

Since the Active Equalizer is connected to your integrated amplifier, preamplifier, or receiver, where the tape recorder is normally connected, extra jacks are provided on the equalizer for the connection of a tape recorder. Refer to FIGURE 7 and follow the next five steps carefully.

1. Turn all power off.
2. Connect the RIGHT channel TAPE IN jack on the equalizer to the RIGHT or "B" channel OUTPUT jack on the tape recorder.
3. Similarly, connect the LEFT channel TAPE IN jack on the equalizer to the LEFT or "A" channel OUTPUT jack of the tape recorder.

4. Connect the RIGHT channel TAPE OUT jack on the equalizer to the RIGHT or "B" channel INPUT (or LINE IN) jack of the recorder.
5. Similarly, connect the LEFT channel TAPE OUT jack on the equalizer to the LEFT or "A" channel INPUT (or LINE IN) jack on the recorder.

NOTE: IF YOUR CONTROL AMPLIFIER HAS TWO TAPE MONITOR CIRCUITS, BE CERTAIN TO CONNECT YOUR TAPE RECORDER TO THE BOSE ACTIVE EQUALIZER, NOT TO THE UNUSED TAPE MONITOR ON YOUR RECEIVER.

Installation of the tape recorder is now complete. To play the tape recorder, simply place the TAPE switch on the 901 Active Equalizer in the MONITOR position (in).

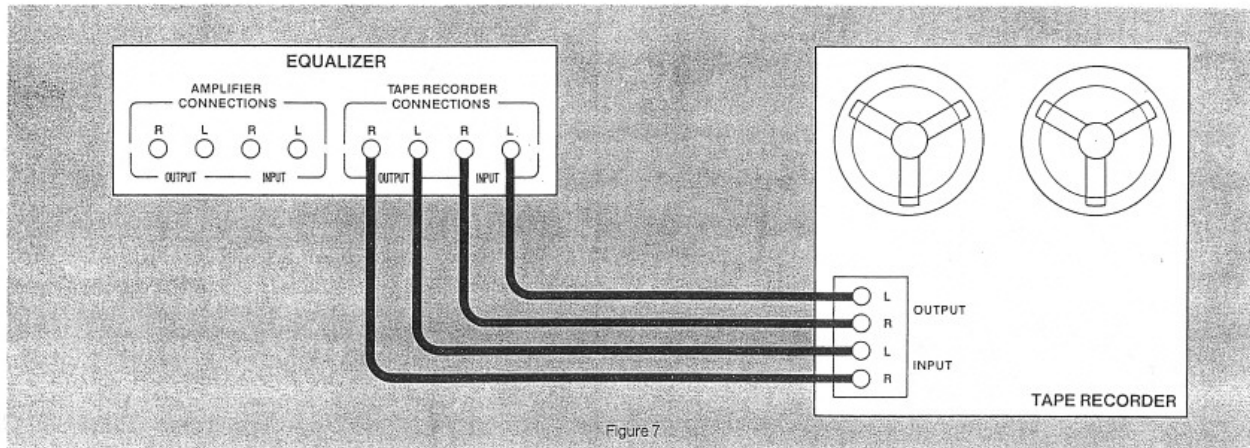

Figure 7

If you wish to play your tape recorder without using the equalizer (for conventional speakers or headphones) and your control amplifier has two tape monitor circuits, an additional connection procedure is required:

1. Connect "Y" connectors to both channels at the tape output connections of your tape recorder.
2. Connect one side of each "Y" connector as described in Steps 2 and 3 of "Connecting Your Tape Recorder."
3. With the remaining output from each channel "Y" connector, connect cables to the unused tape monitor *input* connections of Tape Monitor 2 found on your control amplifier.
4. To play your tape recorder with your 901s, place the tape monitor of your 901 equalizer in the monitor position (in) using the TAPE MONITOR 1 circuit.
5. To play your tape recorder with conventional speakers and headphones, place the TAPE MONITOR 2 switch of your control amplifier on. Your tape recorder will then be connected directly to your high-fidelity system and will play without the equalizer.

NOTE: Contact your BOSE dealer concerning the availability of "Y" connectors and any further connection advice.

#### **B. CONNECTING HEADPHONES AND CONVENTIONAL SPEAKERS**

It is important to realize that the BOSE Active Equalizer introduces substantial boost in the range below 100 Hz and above 5,000 Hz to match the power response of the 90 speakers. Consequently, conventional speakers or headphones if played with the equalizer in the circuit, will sound unnatural with both treble and bass being emphasized.

**MORE IMPORTANTLY, HEADPHONES AND CONVENTIONAL SPEAKERS MAY ACTUALLY BE DAMAGED IF PLAYED WITH THE ACTIVE EQUALIZER IN THE CIRCUIT.**

For this reason, it is important to switch the Active Equalizer out of the circuit by placing the tape monitor switch of your control amplifier in the OFF or NORMAL position when playing conventional speakers or headphones with your high-fidelity system.

†Any speaker system other than the BOSE III or IV system.

## V. Living with your BOSE 901 Loudspeakers

The effect of listening room acoustics is to radically modify the tonal balance of any loudspeaker. This effect can be greater than the difference between two loudspeakers of substantially different cost.

As part of its ongoing research in sound reproduction, BOSE Corporation has carried out an extensive program examining the acoustic properties of a wide range of listening rooms. The development of the 901 Series IV loudspeaker is an important result of this research and development. The 901 Series IV loudspeaker system solves the problem of the effect of the room on speaker performance with a new equalizer design that provides controls specifically designed to compensate for the effects of room characteristics, musical sources, and speaker placement.

A contribution in achieving this new performance is the new driver used with the 901 Series IV. This new driver assembly has an improved efficiency in the range of 10-15 kHz.

Improvements in components, adhesives, and manufacturing techniques have also made possible further improvements in the high-power handling capability of the driver. The power handling capability of the speaker system has been improved to the point that there are no restrictions on the size of the amplifier used with the 901 Series IV in non-commercial applications, providing the fusing recommendations in this owner's manual are followed.

The combination of new equalizer controls, improvements in high-frequency efficiency, and high-power handling capabilities make the 901 Series IV speaker system unusually flexible with respect to location in the listening room, room acoustics, and choice of power amplifier.

### A. SOURCE AND ROOM COMPENSATION CONTROLS

The 901 Series IV Active Equalizer Controls have been designed from a radically different vantage point. Currently available tone controls found on amplifiers and receivers feature bass and treble controls that are primarily designed around established circuits. These circuits were designed without any specific compensation requirement and therefore cannot compensate for the specific effects of room acoustics.

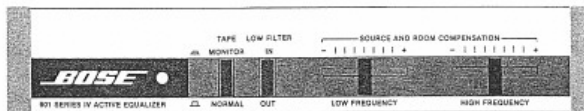

For example, most current bass controls not only adjust the mid-bass normally affected by room acoustics, but also the deep bass and lower midrange. Also, adjusting the treble control, will adjust the extreme highs out of proportion to the upper treble and midrange. The new 901 Series IV equalizer addresses this dilemma with two new controls called Source and Room Compensation Controls.

Certain portions of the midbass of any speaker system will tend to vary dramatically as a function of listening room acoustics. BOSE has addressed this problem with the LOW FREQUENCY CONTROL that provides up to 16 dB of change in the 100 to 400 Hz range. This frequency contouring circuit is designed to provide the compensation required to match the acoustics of your listening room.

The HIGH FREQUENCY CONTROL is a shelving function that begins affecting the sound at 1 kHz and can significantly adjust the speaker's presence and sonic detail over the midrange and high-frequency range without sacrificing performance at the extreme high frequencies. Regardless of the acoustics of your listening room, this control allows the speaker system to achieve the correct spectral balance.

## B. ADJUSTING THE LOW AND HIGH FREQUENCY SOURCE AND ROOM COMPENSATION CONTROLS

1. Select a well-recorded familiar record with a full orchestral passage or a record with a large number of diverse musical instruments that span the entire frequency range. Select a recorded passage that has sustained music over several seconds so you can observe the effects of the controls.
2. Preset the HIGH FREQUENCY Control in the center.
3. Move the LOW FREQUENCY Control back and forth several times over the extremes of the control's range and carefully listen to its effect. You will notice a dramatic change in the basic fullness or body of the sound without changing the deep bass or midrange. Starting with the control at the extreme left, slowly move the knob until the balance of the sound is rich and full, but without excessive heaviness.
4. Next, replay the same passage again and move the HIGH FREQUENCY Control over the extremes of the range several times, listening to its effect. Starting with the control set at the extreme left, slowly move the knob until the sound fills with instrumental detail clarity, and presence.

Note that since no room is typical, it will be rare that the center setting of both controls is used. Accordingly, it is important to realize that it is your adjustment of these controls that will result in the speakers optimum performance.

### LOW FILTER CONTROL

The 901 Active Equalizer features a newly-designed LOW FILTER Control. The LOW FILTER Switch can be used to reduce the lowest two octaves of bass energy without affecting the mid-bass response. This control is most useful in removing record or turntable rumble.

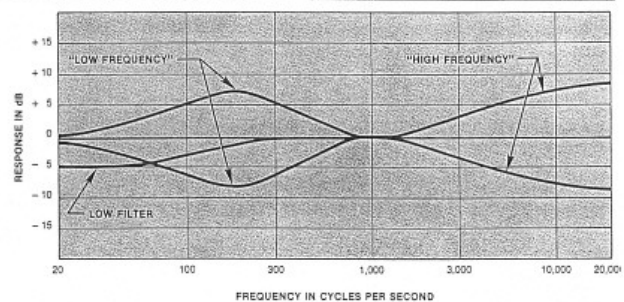

901 IV EQUALIZER CONTROL RESPONSE

## C. SPEAKER PLACEMENT

Several options are possible regarding placement of your 901 in your listening room. Shelving that is deep enough to provide the necessary distances behind and to the side of the speaker system can be used. Make certain the shelving is substantial and not the same shelf used to hold your turntable, as possible acoustic feedback can occur.

Many people choose the attractive pedestals available with the 901 Series IV System. If you choose this method of support instructions are provided with the pedestals for connecting and mounting the speaker system, using the four predrilled holes (A) in the speaker bottom.

Another placement idea is to suspend the speaker system from the ceiling (see Figure 1). This placement method is particularly attractive if wall surfaces are interrupted by windows or doorways or if floor placement is difficult due to furniture or the presence of children.

## Living with your BOSE 901 Loudspeakers

If you decide to hang your speakers, place the Part II speaker on the left side of the room and the Part I speaker on the right side of the room.\* Turn the speakers upside down and place them on a covered surface or rug.

\*Please note that the reversed speaker placement is intentional and is necessary when using electronics products to be introduced by BOSE to operate with the center terminal found on the 901 Series III and IV Loudspeaker.

### THREE-CHAIN OR FOUR-CHAIN MOUNTING

Three-chain mounting utilizes the holes (B) near the front of the cabinet, and a third pilot hole located near the "V" of the cabinet.

When suspending the speaker with four chains, use the four predrilled holes (C) located near the corners of the speaker. Insert four 3/4-inch eyehooks in place. The speaker system weighs 35 pounds and care should be taken to ensure that the speaker is safely supported from the ceiling. A supporting chain should be attached to a structural support, such as a beam or joist.

If you have placed the speakers quite high in your listening room, the sound can be directed downward by angling the rear of the speaker down. The sound will be directed downward after it is reflected off the rear wall. This is done by increasing the length of the rear chain(s) holding the speaker system in place.

### INSTALLING THE RUBBER FEET

The speaker is supplied with four rubber feet and four screws. These feet should be used to prevent possible damage to surfaces such as shelves or tables. Insert the feet with the screws in the four holes (C) located near the corner of the cabinet.

### D. ROOM ACOUSTICS

The acoustical properties of the room (such as the size, shape, construction, and furnishings) play an important part in the quality of sound produced by your high-fidelity system.

A lack of bass response frequently may be attributed to walls of thin panel construction, large openings (e.g., doorway), or excessive window glass, which allow low frequencies to pass through rather than reflecting them into the listening room.

The overly bright sound of acoustically "live" rooms (e.g., those with uncovered floors or scatter rugs, small amounts of furniture, hard walls) can be improved by the addition of rugs and heavy drapery, which also serve to eliminate echoes and standing waves. For acoustically "dead" rooms (e.g., rooms with wall-to-wall carpeting, heavily upholstered furniture and draperies,) furnishings should be rearranged or removed.

The unique controls on your 901 IV Equalizer are especially helpful in compensating for the characteristics of different rooms.

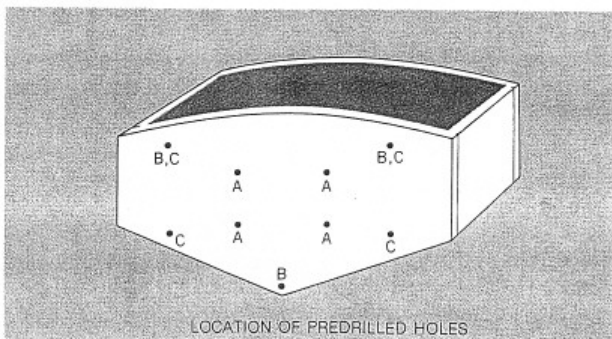

## VI. Technical Information

### A. SPECIFICATIONS

**1. The system is packed in two cartons marked "Part 1" and "Part 2."**

Shipping Weight: Part 1, 45.5 lbs. Part 2, 43.5 lbs.

Carton Dimensions: 25 $\frac{1}{2}$ " x 16" x 14 $\frac{1}{2}$ "

**2. The Speaker**

Dimensions: 21" Wide x 12 $\frac{1}{2}$ " High x 13" Deep

Weight: 35 lbs. Impedance: 8 ohms

**3. Percentages of Reflected and Direct Sound Radiation**

Power radiated by reflection: 89%

Power radiated directly: 11%

**4. Power Handling**

Minimum Recommended Power: 10 watts rms per channel at 8 ohms.

Maximum Recommended Power: No power restrictions on amplifier size when used in non-commercial applications, providing the fusing recommendations are followed.

**5. Speaker Configuration**

**SPATIAL CHARACTERISTICS:** Eight speakers reflecting sound at 30° angles from the wall behind the speaker; one speaker directed into the listening area to provide the optimum ratio of reflected to direct sound and the proper angles of the reflected sound incident upon the listener.

**SPEAKER COMPLEMENT:** Nine matched full-range speakers, utilizing aluminum helically wound voice coils; linear, high-excursion suspension; low impedance (0.9 ohms) voice coils connected in series.

**ENCLOSURE:** Acoustic Matrix™, utilizing three Reactive Air Columns tuned below system resonance and partially isolated individual cells for each driver; air columns emerge through rear of speaker cabinet for maximum efficiency.

**6. The Active Equalizer**

**TAPE MONITOR SWITCH:** Replaces tape monitor switch on receiver or amplifier when equalizer is connected in tape monitor circuit.

**LOW FILTER CONTROL:** Two-position, 5 dB decrease at 40 Hz.

**SOURCE AND ROOM COMPENSATION**

**LOW FREQUENCY CONTROL:** Continuously adjustable slider, ±8 dB adjustment over band from 100 Hz to 400 Hz.

**HIGH FREQUENCY CONTROL:** Continuously adjustable slider, shelving control with range of ±8 dB at 10 kHz.

Dimensions:	2 $\frac{5}{16}$ " High x 5 $\frac{1}{16}$ " Deep x 11 $\frac{3}{8}$ " Wide
Input impedance:	80 kilohms
Harmonic distortion:	< 0.1% (1.0-volt output)
Noise ("A" weighted):	90 dB below 1 volt
Minimum load impedance:	5 kilohms
Maximum output voltage:	2.5 volts
Maximum gain:	21 dB at 16 kHz (center setting)

## Technical Information

---

### B. 110-220 VAC VOLTAGE CONVERSION

The BOSE Series IV Equalizer is designed to operate on one power line voltage only.

Equalizers manufactured for 120 VAC operation are *not* convertible to 240 volt operation except by factory modification. Equalizers manufactured for 240 VAC operation may be converted to 120 VAC operation by BOSE Authorized Factory Service Agencies. (The speakers require no voltage conversion.)

### C. IN CASE OF DIFFICULTY

If you suspect that there is a problem with your 901 system, it is worth a few minutes of your time to determine whether your 901s are defective, and if so, what part of the system is defective.

**If one speaker sounds defective**, DO NOT switch the speaker cables, as this may damage the speaker operating correctly. Instead, disconnect the wire of the speaker suspected of being defective at the amplifier output and reconnect to the amplifier channel operating correctly. (This can generally be done without disconnecting the correctly functioning speaker.) If the speaker system that sounded defective now plays correctly, the difficulty is not in the speakers or in the speaker wiring.

**If bass and high frequencies seem weak**, check to assure that the equalizer is in the circuit.

**If you hear distortion when both speakers are operating at high sound levels** that disappears when you turn the volume down or push the Low Filter switch "In," you are probably overloading the amplifier.

**If the trouble seems to be in the equalizer**, be sure that the system operates properly with the equalizer out of the circuit. This can be determined by disconnecting the equalizer from the circuit. Be certain that all cables are connected properly and that the cables are not defective.

If the trouble still persists, contact your dealer. He will arrange for service or have the unit checked for proper operation. The complete procedure for obtaining service is outlined in the warranty found in SECTION VII of this manual.

### D. CARE AND MAINTENANCE

Your 901 speaker cabinets and equalizer are made with an oil-rubbed walnut veneer finish. Any good grade of furniture polish used for wood finishes can be used in normal dusting and cleaning; however, to maintain the beautiful appearance of your 901s, we suggest occasionally rubbing the cabinet with linseed oil. After rubbing, use a dry cloth and polish off any excess oil.

Grille cloths generally require no care, although they may be carefully vacuumed if necessary.

## VII. Warranty

---

### FULL 5-YEAR WARRANTY

BOSE warrants this unit to be free from defects in materials and workmanship for a period of five years from the original date of purchase. During that period, BOSE will remedy all such defects, without charge for parts or labor, upon return of the unit together with the original sales receipt or other proof of purchase to BOSE or to an authorized BOSE service agency. This warranty does not extend to damage resulting from improper installation, misuse, neglect or abuse, or to exterior appearance.

#### **IN NO EVENT SHALL BOSE BE LIABLE FOR INCIDENTAL OR CONSEQUENTIAL DAMAGES.**

Should this unit fail within the warranty period, you should contact your nearest BOSE dealer for service instructions. The dealer may ask you to return the unit together with proof of purchase to him, or direct you to return the unit together with proof of purchase to the nearest authorized BOSE service agency. Alternatively, you may elect to send the unit directly to BOSE by carefully following this procedure:

1. Obtain a "Return Authorization" number from the BOSE Customer Service Department, 100 The Mountain Road, Framingham, Massachusetts 01701.
2. Return the unit together with proof of purchase to BOSE Corporation, 100 The Mountain Road, Framingham, Massachusetts 01701, *freight prepaid*, in its original shipping carton. If you need a new carton, your dealer or BOSE Corporation will provide a free replacement carton. Any damage in transit due to improper packing is not covered by the warranty and will not be recognized as an insurance claim by the transportation companies.

Your unit will be repaired and returned to you at BOSE's expense. If the defects cannot be repaired after a reasonable number of attempts by BOSE to do so, you may elect to receive a refund or replacement, but only if the unit is returned to BOSE free and clear of all liens and other encumbrances.

This warranty gives you specific legal rights, and you may also have other rights which vary from state to state. Some states do not allow the exclusion or limitation of incidental or consequential damages, so that the above limitation may not apply to you.

---

***BOSE***<sup>®</sup>

THE MOUNTAIN • FRAMINGHAM, MASS. 01701

Printed in U.S.A. 111432